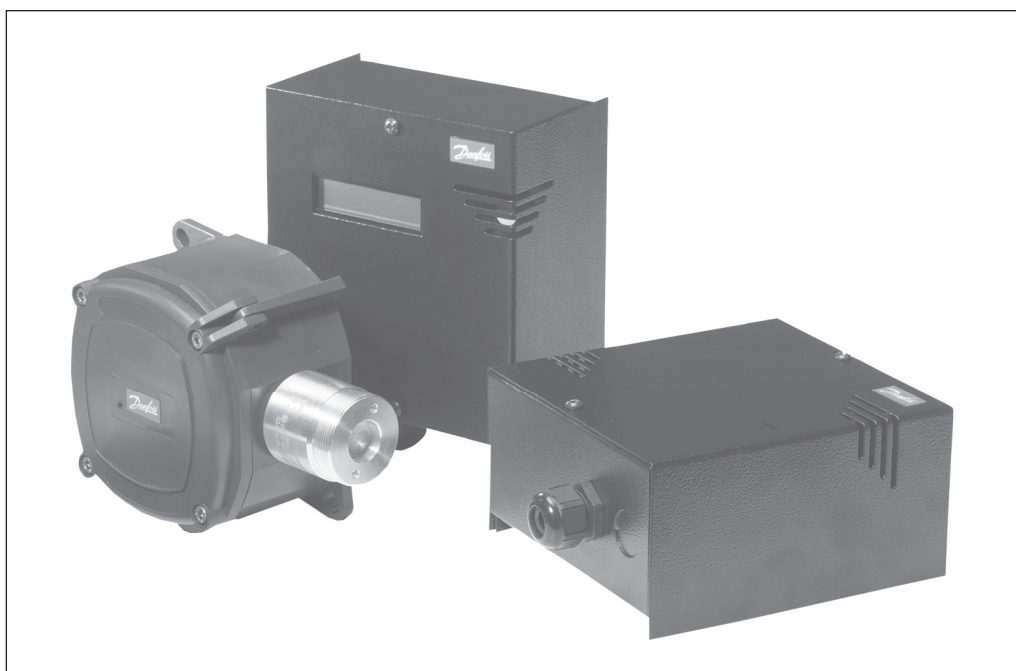

Gas Detection Sensor
type GDA, GDC, GDHC, GDHF, GDH

Contents

	Page
Introduction.....	3
Features.....	3
Technical data	3
Electrical connection	4
Design.....	5
Sensor technology	6
Electrochemical Sensors - EC	6
Semi-conductor – SC	6
Catalytic - CT	6
Infrared - IR	6
Product range	7
Functions - all models	7
Alarm	7
Analog Output	8
LCD display	8
Upper Line	8
Lower Line	8
Mother PCB	8
GD connected to Danfoss m2 monitoring	9
Ordering.....	11
Maintenance/Replacement of the sensor boards.....	11
Dimensions	12

Introduction

Danfoss Gas Detection Sensor Transmitters, type GD are a range of products designed to meet all industrial refrigeration and air conditioning application requirements.

GD detects a wide range of commonly used refrigerants including Ammonia, Carbon Dioxide, Halo-Carbons and Hydro-Carbons.

GD sensors incorporate an interchangeable precalibrated sensor board, which makes it very easy to replace the sensor when service or the calibration procedure is required.

Features

- GD is specifically developed for refrigeration applications.
- Interchangeable precalibrated sensor board
- Optional models: LCD display, IP 65 enclosure, EExd (Explosion Protected)
- Can operate as stand alone product. No additional add on is required
- Linear analog outputs, current (mA) / volt (V) proportional to the gas concentration.
- Two digital outputs. Low Level and High Level Alarm
- Optional NO or NC and different delay setting for Level Alarms
- Manual or Auto reset optional
- Alarm levels can be set locally.
- GD can be connected directly to a Danfoss m2 monitoring unit. No additional add on is required.
- Available with a range of different sensor technologies to monitor industrial refrigeration gases:
 - Electro-Chemical
 - Semi-Conductor
 - Catalytic
 - Infra-Red

Technical data
Refrigerants:
Ammonia (R 717)

- Type GDA:
- 0-100 ppm
 - 0-1,000 ppm
 - 0-10,000 ppm
 - 0-30,000 ppm

Carbon Dioxide (R 744)

- Type GDC
- 0-10,000 ppm

Halo-Carbon - HCFC (R 22, R 123)

- Type GDHC
- 0-1,000 ppm

HFC (R 404A, R410A, R134A, R 407C, R 507)

- Type GDHF
- 0-1,000 ppm

Hydro-carbon
Propane (R 290, R 600, R 600A, R 1270)

- Type GDH
- 0-5,000 ppm

Technical data
(Continued)*Temperature range*Standard, LCD display, IP 65 and EExd (fig. 2):
-20°C/+50°C (-4°F/122°F)Low temperature model:
-40°C/+50°C (-40°F/122°F)*Enclosure*Standard: IP 30 (NEMA 1)
LCD display: IP 30 (NEMA 1)
IP 65: IP 65 (NEMA 4)
EExd: IP 65 (NEMA 4)
Low temp.: IP 40 (NEMA 2)*Cable connection*1 gland for 6-13 mm cable (0.2"-0.5")
1 Ø 20 mm (0.8") hole with blanking plug.
1 extra gland can be fitted (only Standard, LCD display, IP 65 and EExd).*Weight*Standard: 1015 grams (2.24 lb)
LCD display: 1045 grams (2.30 lb)
IP 65: 778 grams (1.72 lb)
EExd: 4200 grams (9.26 lb)
Low temp.: 520 grams (1.15 lb)*Approvals*

CE:

EN55011: 1998,

EN61326: 1996

Following the provisions of 89/336/EEC, EMC directives and, Cenelec

EN61010-2 : 2001

Following the provisions of 73/23/EEC, Low Voltage directive (LVD)

ATEX for EExd model:

Directive 94/9/EC Group 2, Category 2, G and D, Zones 1 and 2.

Electrical connectionAll terminals will accept 0.5-1.5 mm² (20-15 AWG)*Supply voltage*12- 24 V a.c
12- 30 V d.c
Max load : 4 W*Analog output*4-20 mA Max 400Ω
0-10 V Min. 10 kΩ
0-5 V Min. 10 kΩ*RS 485 Communication*

To Danfoss m2 monitoring unit

Digital output – volt free contacts

Load: 1 A, 24 V a.c/d.c

Design

The GD product range is designed in a very flexible way with a mother PCB (Print Circuit Board) and an interchangeable precalibrated sensor PCB.

The mother PCB is the same for all GD models independent of the refrigerant or sensor technology. On the mother PCB individual settings can be selected to meet local application requirements.

The sensor PCB is always precalibrated and dedicated to the actual refrigerant and ppm range. Danfoss has in advance picked the most appropriate sensor making it easy to obtain safe detection and avoid false alarms from other gases present.

Because of the interchangeable precalibrated sensor PCB, it is very easy to replace the sensor when service or the annual calibration procedure is required (fig.1).

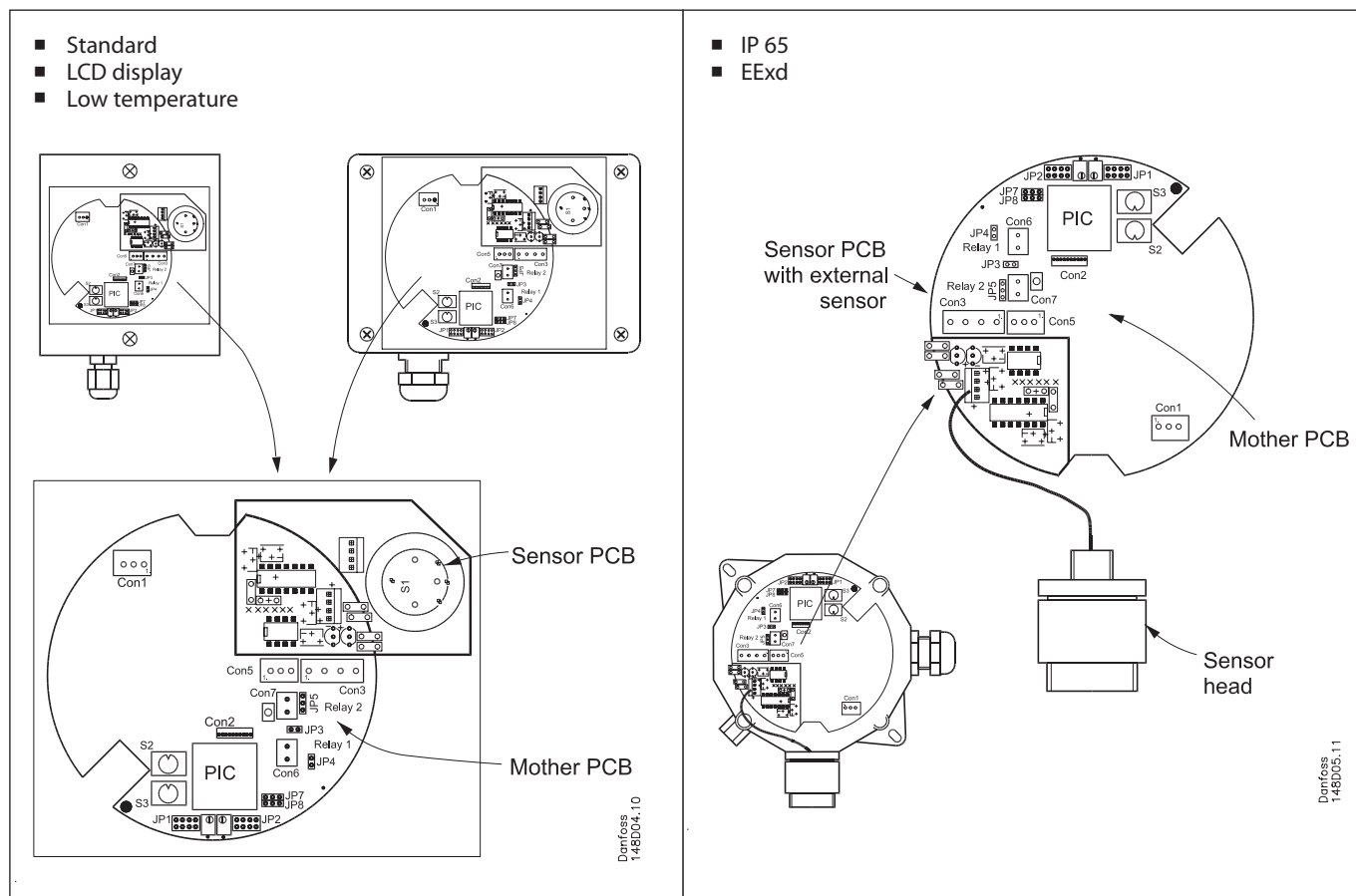

fig. 1

Sensor technology

Danfoss has, depending on actual ppm range and refrigerant, selected the most appropriate sensor for the target refrigerant gas. This makes it much easier to select the Gas Detector. When the refrigerant and actual ppm range has been decided, Danfoss GD product range makes it easy to pick out the right product.

Below is a brief introduction to the GD sensors.
For further information - please contact Danfoss.

Electrochemical Sensors - EC

EC are used mainly for toxic gases and are suitable for ammonia but not for the other refrigerants. They are very accurate and tend to be used principally for toxic gases which cannot be otherwise detected or where high levels of accuracy are needed. They were relatively expensive with a short life span. However sensors are now available to cover the key range of 0-1,000 ppm and with a longer lifetime of about 2 years in clean air. Exposure to large ammonia leaks or constant background ammonia will shorten the sensor life. These are ideal for ammonia in the key range of 0-1,000 ppm. They are subject only to rare cross interference. EC may react to sudden large humidity changes but quickly settle.

Semi-conductor - SC

SC can be used for a wide range of gases including combustible, toxic and refrigerant gases. It is claimed that they perform better than the CT type in the detection of combustible gases at low concentrations, up to 1,000 ppm. These are low-cost, long life, sensitive, stable, resistant to poisoning and can be used to detect a large range of gases including all the CFC, HCFC, HFC refrigerants, ammonia and hydrocarbons. However, they are not selective and are not suited to detecting a single gas in a mixture or for use where high concentrations of interfering gases are likely to be present. Cross interference problems are minimized by using a special sensor version with a filter, calibrating for the specific gas and incorporating a delayed response.

Catalytic - CT

CT sensors have been mainly used for combustible gases including ammonia. CT are relatively low-cost, well established and understood and they have a good life span, up to 5 years. The response time is about 20-30 seconds. They can be subject to poisoning in certain applications but not generally in refrigeration and are more effective at gas levels of above 1,000 ppm.

Infrared - IR

IR sensors when first introduced were specific to a single gas and therefore not suitable for applications involving monitoring more than one gas. They were very selective and accurate - reading down to one part per million. IR was typically used where a high level of accuracy and specificity is required. This very precision in performance ensures that they are expensive.

Product range

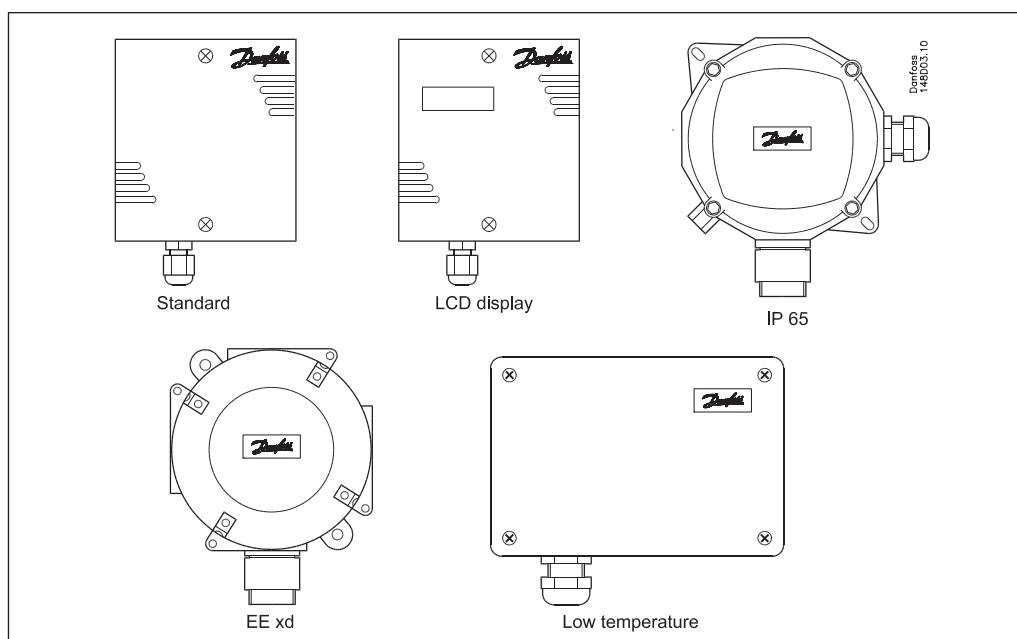

fig. 2

- Standard**
 Basic standard model for machine/engine rooms and cold rooms
 - Standard with LCD display**
 Basic standard model for machine/engine rooms with the actual reading of present ppm level in the room and Alarm messages.
 - IP 65**
 Like Standard but used in applications where water jets from any direction is possible. The sensor is mounted in an external Stainless Steel or Aluminium head.
 - EExd**
 Like Standard but applicable in explosive areas Zone 1 and 2 and higher IP(NEMA). The sensor is mounted in an external Stainless Steel or Aluminium head.
 - Low temperature**
 Like Standard but applicable in applications where air temperature is below -20°C (-4°F) and the IP (NEMA) is higher.
- All the models listed have exactly the same function.

Functions - all models

All GD models shown in fig. 1 have the same basic functions. All settings are done by means of jumper settings on the mother PCB. See fig. 3 and 4, for details on the mother PCB. For detailed information on how to configure Alarm setting - please see the instruction RI7HA.

Alarm

All GD sensors can detect 2 alarm levels and give alarm via 2 volt free contacts. When an alarm has been detected a yellow LED (Low Level Alarm) or a red LED (High Level Alarm) will go ON. All GD sensors have been preset by the factory, to realistic Low/High values related to the actual ppm range of the GD model. The actual Low and High Alarm ppm values can be read on the external GD label.

The 2 volt free contacts can be set individually to either Normally Open (NO) or Normally Closed (NC).

All GD sensors are factory set to NO

Both Low and High Level Alarm can be delayed individually before the 2 volt free contacts are activated. This is useful when cross interference from other gasses may occur. The delayed response time can be set to 0, 1, 5 or 10 minutes.

All GD sensors are factory set to 0 minutes. (GDHC and GDHF is 300 sec.)

When the GD sensors have detected a Low or High Level Alarm an option for having these alarms with Manual reset or Auto Reset is possible. With the option Manual reset selected, a push button on the mother PCB must be activated to release the Low or High Level Alarm. With the option Auto reset selected, the release of the Low or High Level Alarm is done automatically.

All GD sensors are factory set to Auto Reset.

All GD sensors have been preset by the factory to realistic values related to the actual ppm range of the GD model. The actual Low and High alarm ppm limits can be read from the external GD label.

The factory preset values can be adjusted, with a voltmeter measuring the 0-5 V d.c output (fig. 5). 0V corresponds to the min. ppm range (e.g. 0 ppm) 5V corresponds to the max. ppm range (e.g. 1000)

Example:

If a setting of 350 ppm is required the voltage shall be set to 1.75 V (35 % of 5 V)

Functions - all models
(continued)

Analog Output

All GD sensors will continuously generate a linear analog output, proportional to the gas concentration. The signal is available as 4-20 mA, 0-10 V and 0-5 V. All are available at the same time (fig. 3).

LCD display

The model with the LCD display will continuously display the actual present ppm level in the room and the Alarm messages.

Upper Line:

Actual present ppm level (e.g: "580 ppm").

Lower Line:

Alarm status.

4 text messages are possible - only one at a time:

"No Alarm"	Neither Low Level Alarm nor High Level Alarm active.
"Lo Alarm on"	Low Level Alarm active.
"Lo,Hi Alarm on"	Both Low Level Alarm nor High Level Alarm active.
"Hi Alarm on"	High Level Alarm active.

Mother PCB

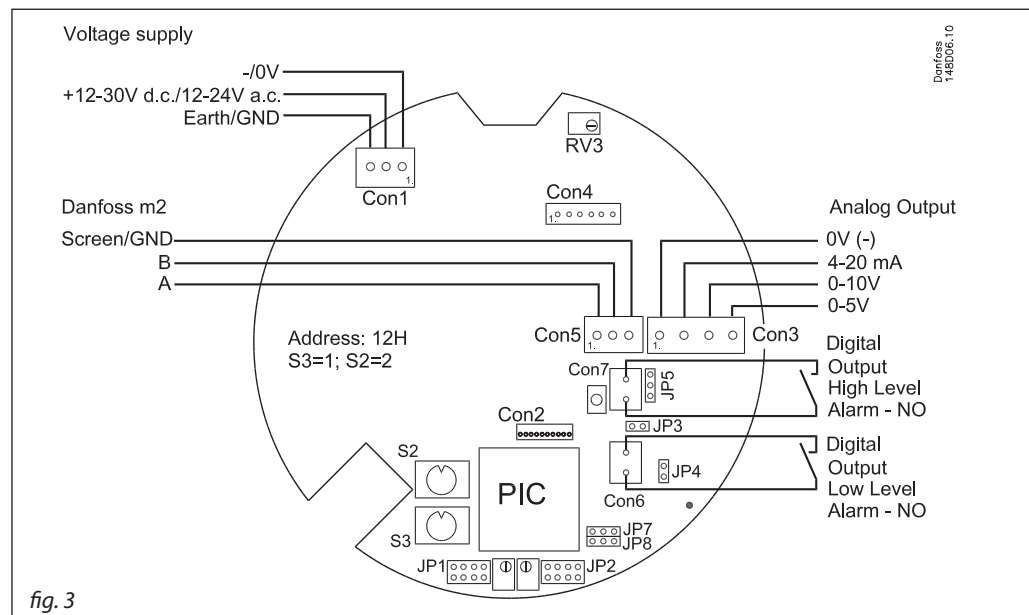

fig. 3

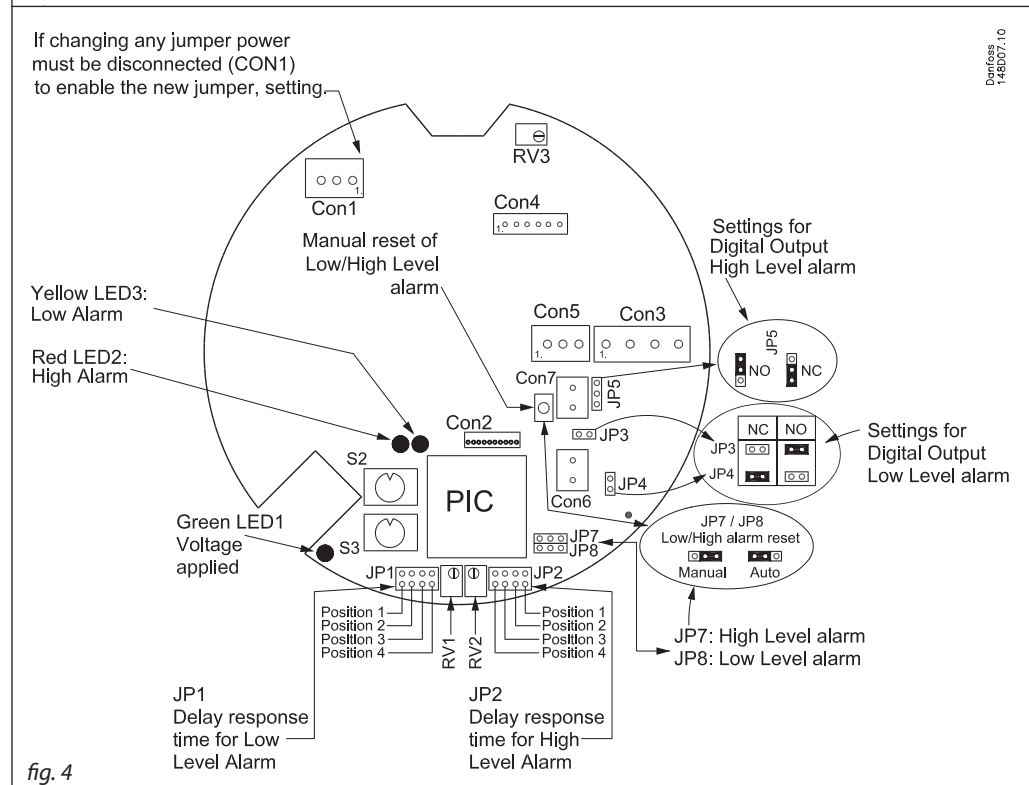

fig. 4

Mother PCB
(Continued)

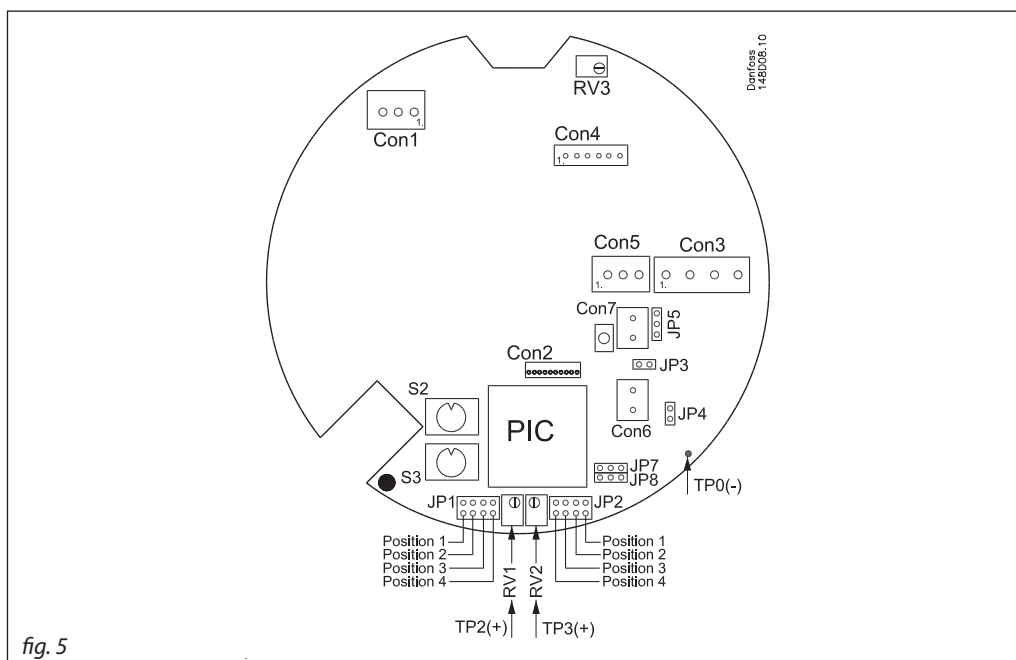

fig. 5

GD connected to Danfoss m2 monitoring

Danfoss offers the possibility of connecting every GD, independent of model, via the built-in RS 485 Bus communication, directly to the Danfoss m2 monitoring unit.

Up to 31 GD sensors can be connected via a two-core screened communication cable (fig. 6). Every GD sensor needs a unique address number which must be selected. The sensor address is set by S2 and S3, adjusting these dials between

0 and F will give the sensor its own address as shown in fig. 7.

A conversion chart between m2 channel numbers and the hexadecimal address of the ST-IAM 2 is attached. Power must be removed when setting the addresses on the GD sensor. If more than 31 units are needed, please contact Danfoss for further information.

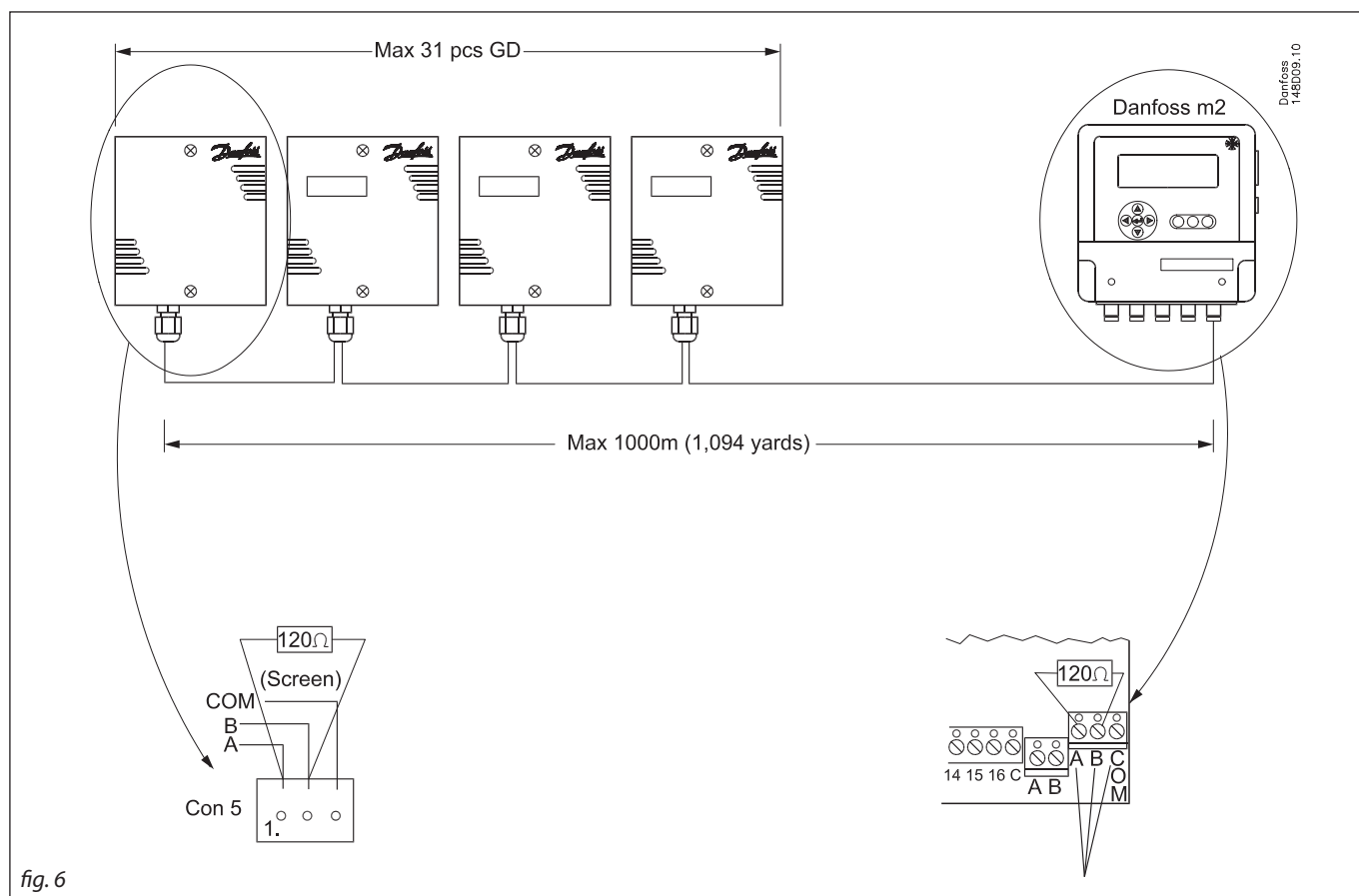

fig. 6

GD connected to Danfoss m2 monitoring
(Continued)

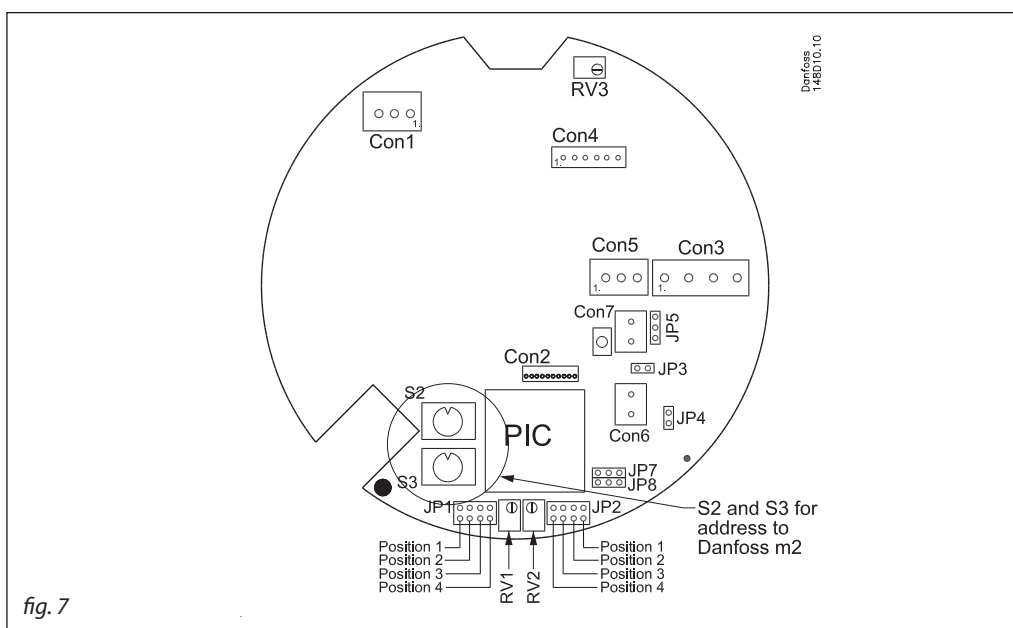

fig. 7

Channel on Danfoss m2	S3	S2	Channel on Danfoss m2	S3	S2	Channel on Danfoss m2	S3	S2
1	0	1	34	2	2	67	4	3
2	0	2	35	2	3	68	4	4
3	0	3	36	2	4	69	4	5
4	0	4	37	2	5	70	4	6
5	0	5	38	2	6	71	4	7
6	0	6	39	2	7	72	4	8
7	0	7	40	2	8	73	4	9
8	0	8	41	2	9	74	4	A
9	0	9	42	2	A	75	4	B
10	0	A	43	2	B	76	4	C
11	0	B	44	2	C	77	4	D
12	0	C	45	2	D	78	4	E
13	0	D	46	2	E	79	4	F
14	0	E	47	2	F	80	5	0
15	0	F	48	3	0	81	5	1
16	1	0	49	3	1	82	5	2
17	1	1	50	3	2	83	5	3
18	1	2	51	3	3	84	5	4
19	1	3	52	3	4	85	5	5
20	1	4	53	3	5	86	5	6
21	1	5	54	3	6	87	5	7
22	1	6	55	3	7	88	5	8
23	1	7	56	3	8	89	5	9
24	1	8	57	3	9	90	5	A
25	1	9	58	3	A	91	5	B
26	1	A	59	3	B	92	5	C
27	1	B	60	3	C	93	5	D
28	1	C	61	3	D	94	5	E
29	1	D	62	3	E	95	5	F
30	1	E	63	3	F	96	6	0
31	1	F	64	4	0	97	6	1
32	2	0	65	4	1	98	6	2
33	2	1	66	4	2	99	6	3

Danfoss m2 literature:

Technical Leaflet : RB8BA
 Manual : RS8AN
 Instruction : RI8BM

Ordering

Type of gas	All models					Standard	With LCD display	IP 65 version	EExd	Low Temp -40/+40C
	Danfoss Type	Range [PPM]	Alarm limits. Low/High [PPM]	Response Delay [s]	Sensor type					
						Code No.				
Ammonia - NH₃										
R 717	GDA EC 100	0-100	25/35	0	Electro-chemical	148H5000	148H5001	148H5002	148H5003	148H5004
	GDA EC 1000	0-1,000	500/900	0	Electro-chemical	148H5010	148H5011	148H5012	148H5013	148H5014
	GDA SC 10000	0-10,000	5000/9000	0	Semi-Conductor	148H5020	148H5021	148H5022	148H5023	148H5024
	GDA CT 30000	0-30,000	500/10000	0	Catalytic	148H5030	148H5031	148H5032	148H5033	148H5034
Carbon Dioxide - CO₂										
R 744	GDC IR 10000	0-10,000	5000/9000	0	Infrared	148H5070	148H5071			
Halo-Carbon										
HCFC (R 22, R 123)	GDHC SC 1000	0-1,000	500/900	300	Semi-Conductor	148H5100	148H5101	148H5102		148H5104
HFC (R 404A, R410A, R134A, R 407C, R 507)	GDHF SC 1000	0-1,000	500/900	300	Semi-Conductor	148H5110	148H5111	148H5112		148H5114
Hydro-carbon										
(R 290(Propane), R 600, R 600A, R 1270)	GDH CT 5000	0-5,000	2000/4000	0	Catalytic	148H5160	148H5161		148H5163	

Maintenance/Replacement of the sensor boards.

Danfoss Type designation	Code No.	Description
GDA EC 100 sensor PCB	148H5200	GDA EC 100 Sensor board.
GDA EC 1000 sensor PCB	148H5201	GDA EC 1000 Sensor board.
GDA SC 10000 sensor PCB	148H5202	GDA SC 10000 Sensor board.
GDA CT 30000 sensor PCB	148H5203	GDA CT 30000 Sensor board.
GDC IR 10000 sensor PCB	148H5204	GDC IR 10000 Sensor board.
GDHC SC 1000 sensor PCB	148H5205	GDHC SC 1000 Sensor board.
GDHF SC 1000 sensor PCB	148H5206	GDHF SC 1000 Sensor board.
GDH CT 5000 sensor PCB	148H5207	GDH CT 5000 Sensor board.
GDA EC 100 sensor PCB Ext	148H5208	GDA EC 100 Sensor board and External Sensor Head
GDA EC 1000 sensor PCB Ext	148H5209	GDA EC 1000 Sensor board and External Sensor Head
GDA SC 10000 sensor PCB Ext	148H5210	GDA SC 10000 Sensor board and External Sensor Head
GDA CT 30000 sensor PCB Ext	148H5211	GDA CT 30000 Sensor board and External Sensor Head
GDHC SC 1000 sensor PCB Ext	148H5212	GDHC SC 1000 Sensor board and External Sensor Head
GDHF SC 1000 sensor PCB Ext	148H5213	GDHF SC 1000 Sensor board and External Sensor Head
GDH CT 5000 sensor PCB Ext	148H5214	GDH CT 5000 Sensor board and External Sensor Head

Dimensions

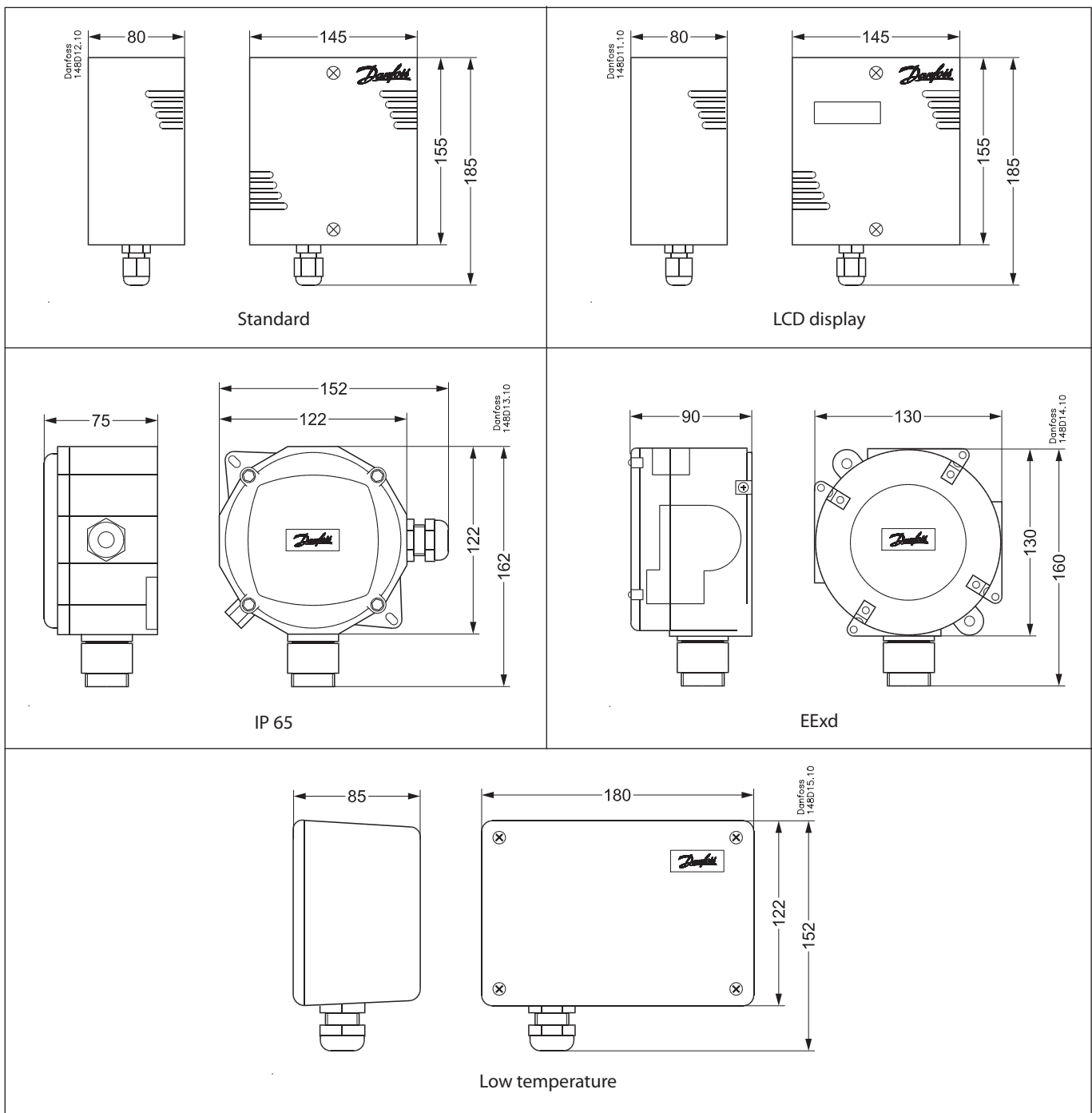

Danfoss can accept no responsibility for possible errors in catalogues, brochures and other printed material. Danfoss reserves the right to alter its products without notice. This also applies to products already on order provided that such alterations can be made without consequential changes being necessary in specifications already agreed. All trademarks in this material are property of the respective companies. Danfoss and the Danfoss logotype are trademarks of Danfoss A/S. All rights reserved.